	FIRE PROTECTION CURTAIN DOOR type: MARC-Ok + EI60	number: MM_Ok-5en
	FIRE PROTECTION DEVICE CHARACTERISTICS	revision: 04.2023

1. DEVICE REQUIREMENTS

1.1 GENERAL REQUIREMENTS

- fire protection doors are construction products defined in the EN 16034:2014-11 harmonised product reference standard. Therefore, they must be labelled with the “CE” mark, and the prerequisite for marketing them is the manufacturer’s obligation to issue a related Declaration of Performance which indicates their intended use in a building,
- the Declaration of Performance issued for fire protection doors should have parameters specified for at least one of the following essential fireproof product characteristics in compliance with the product reference standards, i.e. EN 16034:2014-11 and EN 13241+A2:2016-10:
 - fire resistance,
 - ability to release and durability of the ability to release,
 - self-closing,
 - durability of self-closing against degradation,
 - resistance to wind load;

1.2 REQUIREMENTS FOR BUILDING/INSTALLATION CONDITIONS

- possibility to install in construction partitions made of various materials,
- low height of the lintel required to be installed,
- both indoor and outdoor application,
- possible assembly in tandem with a gate/shutter without fire resistance capability,
- in the case of outdoor location, possibility of mounting on spacer brackets to avoid disassembling the building thermal insulation layer,
- can be used as conveyor system closures;



1.3 REQUIRED DEVICE PARAMETERS

- fire resistance class range as per PN-EN 13501-2:2016: **EI130, EI230, EI160, EI260, EW120-005, EW120-006**
- for all fire resistance classes - a design featuring a single rolling curtain thickness **16mm**;
- resistance to wind load as per PN-EN 12424:2002: **1 or 2**,
- use category (number of working cycles) as per EN 16034:2014-11: **C0, C1 or C2**,
- anti-corrosion class as per PN-EN ISO 12944-2:2018: **C1, C2, C3, C4 or C5**,
- acoustic insulating power as per PN-EN ISO 717-1:2013: at least **20 dB**,
- curtain weight: up to **6 kg/m²** – for class EI60,

1.4 REQUIREMENTS FOR DEVICE DESIGN/EQUIPEMENT

- possibility to manufacture in smoke-proof version class **S_a** and **S₂₀₀** as per PN-EN 13501-2:2016,
- curtain elements come with the possibility of finishing the surface in any colour from the RAL palette or come in a stainless version,
- possibility to design curtain (of smaller dimensions) with a thermal fuse trigger instead of an electric drive and detectors connected to the SAP system,
- doors with a thermal fuse trigger must be equipped with a system / protection (cushioning-retracting spring) to prevent the shell from dropping too rapidly, so as not to pose a risk of an injury,
- possibility to connect a wide range of electric equipment such as fire alarm systems, curtain position monitoring, access control,
- in case the curtain is mechanically damaged, it should be possible to repair/regenerate it without dismantling the entire curtain with the shaft,
- the curtain manufacturer should provide an extended technical description of the device (in section 2 of this Fire Protection Device Characteristics) as well as the Application, Operation and Maintenance Manual to ensure correct and safe assembly, installation, operation, maintenance and disassembly;



 	FIRE PROTECTION CURTAIN DOOR type: MARC-Ok + EI60	number: MM_Ok-5en
	FIRE PROTECTION DEVICE CHARACTERISTICS	revision: 04.2023

2. DEVICE DESCRIPTION

The fire protection curtain door type MARC-Ok + EI60 consists of the following basic components:

- curtain,
- guides,
- curtain shaft,
- shaft brackets
- VIC type drive.

The configuration of the set of electrical equipment depends on the customer's order.

The MARC-Ok + EI60 curtain door has a multi-layer structure, and the thickness of all layers is approx. 16 mm. The upper section of the curtain is attached to the shaft made of a steel tube as per PN-EN 10219-2:2000, through a 20 x 2 mm flat bar made of steel grade DX51D+Z275 as per PN-EN 10346:2015-09, with PH2 4.8 x 40 mm self-tapping screws.

The outer layers of the curtain are bonded together along its bottom. Inside the bonded materials and along the entire clear opening length plus 30 mm from each edge, there is a door counterweight unit made from a dia. 30 mm steel bar, grade S235JR as per PN-EN 10025-2:2019-11.

Two shaft brackets are attached to the lintel of the building partition, each, as a standard, mounted with two 10 x 140 mm ring anchors, through 12,2 mm diameter steel washers.

The anchoring element type depends on the building partition material.

On one side, a UCF 200 series bearing is attached to the shaft bracket using M12 (ISO 10642) screws with M12 (PN-EN 4032:2013) nuts. A VIC tubular drive is attached inside the shaft, on the opposite side.

In the MARC-Ok curtain doors of width and height not exceeding 2,5 m, gravitational drive units can be used. In such cases, doors are actuated with a thermal fuse trigger. A torsion spring located in the shaft ensures a constant closing speed, and door re-opening does not require using any additional elements, e.g. cranks.

The curtain shaft and brackets are enclosed within a cover. The shaft cover is made of galvanised steel sheet, thickness 0,7 – 1,0 mm, grade DX51D+Z275 as per PN-EN 10346:2015-09, and consists of two parts. In the bottom enclosure section, there is a 35 - 40 mm wide gap through which the curtain is routed.

Vertical curtain edges are equipped with slides made of M6 x 20 rivet nuts and mounting plates running in profiled guides.

The guide section is 80 x 120 mm and comprises the wall-side section, mid section, fire-proof panels and a fascia piece. Wall-side and mid sections are made of galvanised steel sheet, grade DX51D+Z275 as per PN-EN 10346:2015-09, thickness 1,5 – 2,0 mm. On the outside, steel guide elements are protected with fire-proof panels type PRO_{MM3}, thickness 20 mm. The guides are standard attached to a building partition using 10 x 112 mm frame anchors spaced every 450 - 550 mm.

The anchoring element type depends on the building partition material.

The guides cover is made from 0,7 mm galvanized steel sheet.

In the case of electrically driven curtain doors, the curtain is wound on a shaft and held open by a brake or a self-locking drive gear. In case a fire hazard alarm is detected, the curtain is released and moved to the closed position.

In the case of a spring-loaded curtain door, the fire protection curtain is wound on a shaft and held open by a thermal fuse trigger which, at approx. 74°C is released and the curtain unfolds to close the fire zone.



 ASSA ABLOY	FIRE PROTECTION CURTAIN DOOR type: MARC-Ok + EI60	number: MM_Ok-5en
	FIRE PROTECTION DEVICE CHARACTERISTICS	revision: 04.2023

3. DRAWINGS

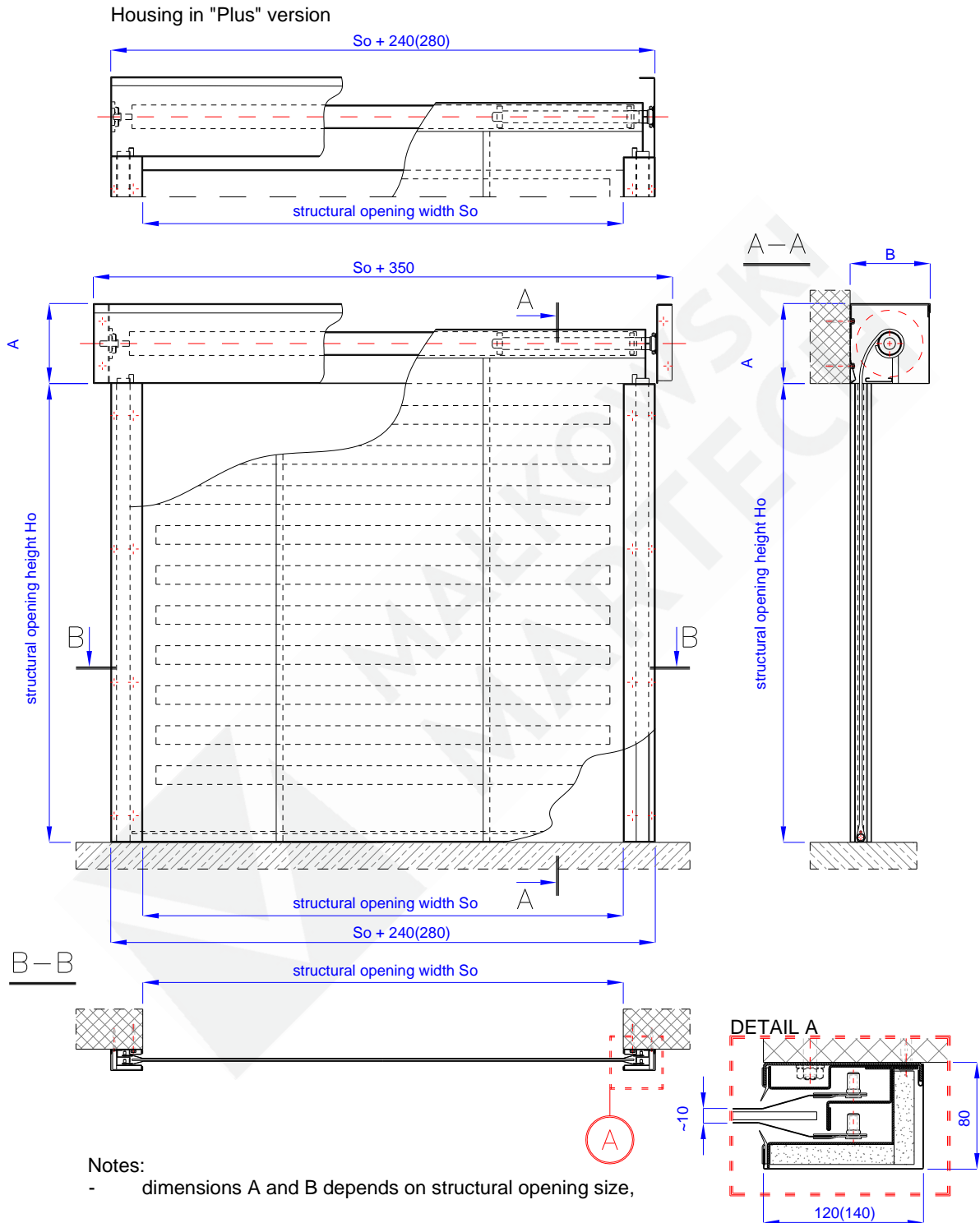



Fig. 1 – Fire protection curtain door MARC-Ok EI60



 	FIRE PROTECTION CURTAIN DOOR type: MARC-Ok + EI60	number: MM_Ok-5en
	FIRE PROTECTION DEVICE CHARACTERISTICS	revision: 04.2023

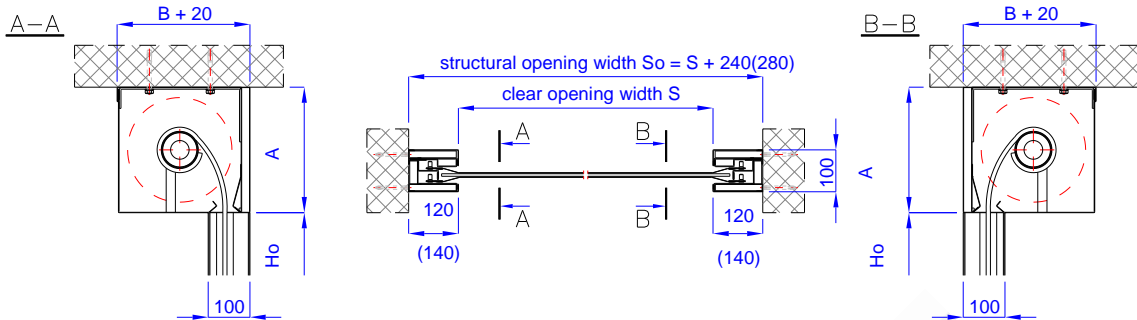

Fig. 2 – Fire protection curtain door MARC-Ok EI60, corridor (niche) mounting
- no lintel and both reveal

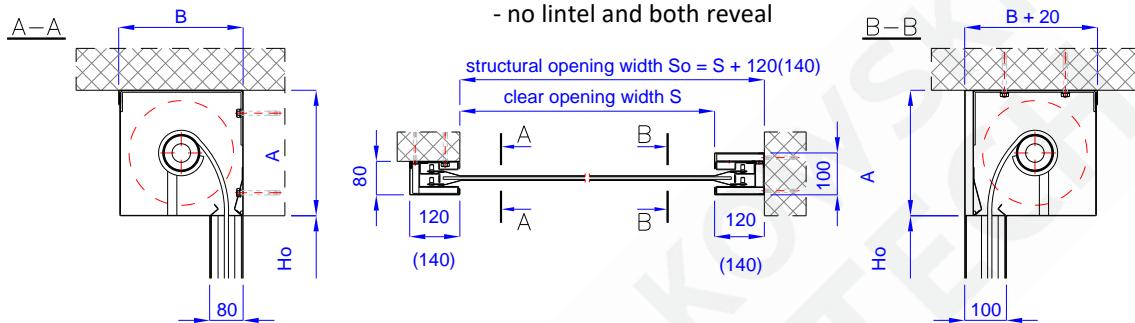

Fig. 3 – Fire protection curtain door MARC-Ok EI60, mixed mounting
- no lintel and reveal on the right side

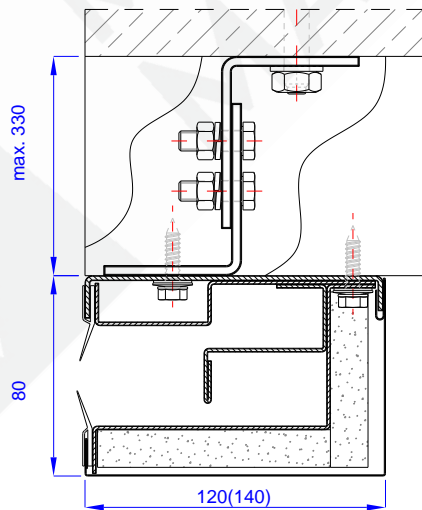



Fig. 4 – Guides mounted on spacer brackets – intermediate installation



 	FIRE PROTECTION CURTAIN DOOR type: MARC-Ok + EI60	number: MM_Ok-5en
	FIRE PROTECTION DEVICE CHARACTERISTICS	revision: 04.2023

4. DEVICE SPECIFICATION

Name	Fire-protection curtain door
Type	MARC-Ok
Fire-resistance class [as per PN-EN 13501-2:2016]	EI₁₄₅, EI₁₆₀, EW₁₂₀
Manufacturer	Małkowski-Martech S.A.
Certificate of Constancy of Performance	2775-CPR-006, -005
Operating manual document	Use, Operation and Maintenance Manual

STRUCTURAL AND QUALITY-RELATED PARAMETERS	(S – standard, O – option, Z – on request)	
Curtain weight	6,0 [kg/m ²]	
Curtain thickness	16,0 [mm]	
Dimensions [clear opening, W x H]	< 12 000 x 10 000 [mm] (12 000 - 18 000) x 10 000 [mm] > 18 000 x 10 000 [mm]	S O Z
Minimum lintel clear height	350 [mm]	S
Installation location	internal external [installed inside the building] external [installed on the building exterior]	S S O
Installation requirements	wall-mounted / ceiling-suspended hallway installation [recessed] mixed installation [recessed wall mounting] intermediate installation [mounted on spacers]	S S S S
Tandem installation	with a non-fire-rated gate / curtain	O
Using category [as per EN 16034:2014-11]	C0 [1 – 499] C1 [500 – 9 999], C2 [10 000 – 49 999]	S O
Resistance to wind load [as per PN-EN 12424:2002]	1 [≤ 300 Pa] 2 [≤ 450 Pa]	S O
Anti-corrosion class [as per PN-EN ISO 12944-2:2018]	C1, C2, C3 C4, C5	S O
Smoke-proof version [as per PN-EN 13501-2:2016]	-	O
Acoustic insulating power [as per PN-EN ISO 717-1:2013]	20 [dB]	S
Ex-proof version [as per PN-EN, ATEX]		Z
Stainless version [as per PN-EN ISO 10088-1]		Z
Conveyor system closures [requires power drive and control module]	with transport line interruption for the curtain without transport line modification	S O
Covers colour	galvanized RAL 7035, 9002, 9010 any RAL palette	S S O
Drive unit type [the application feasibility of specific drive units depends on the door size]	electric [internal] gravitational - with thermal fuse trigger [up to 2500 x 2500 opening size]	S S
Controller - fire alarm control panel [as per PN-EN 54-2:1997+AC:1999+A1:2006]	w/UPS, pre-wired with the field fire alarm system and/or local smoke/heat detectors	O
Electrical components [available only with a fire alarm control panel]	technical key switch electromagnetic holder detectors [smoke or heat, smoke and heat] leaf open and/or closed position sensor signalling device [sounder, optical]	S O O O O



 ASSA ABLOY	FIRE PROTECTION CURTAIN DOOR type: MARC-Ok + EI60	number: MM_Ok-5en
	FIRE PROTECTION DEVICE CHARACTERISTICS	revision: 04.2023

5. ELECTRICAL DIAGRAM

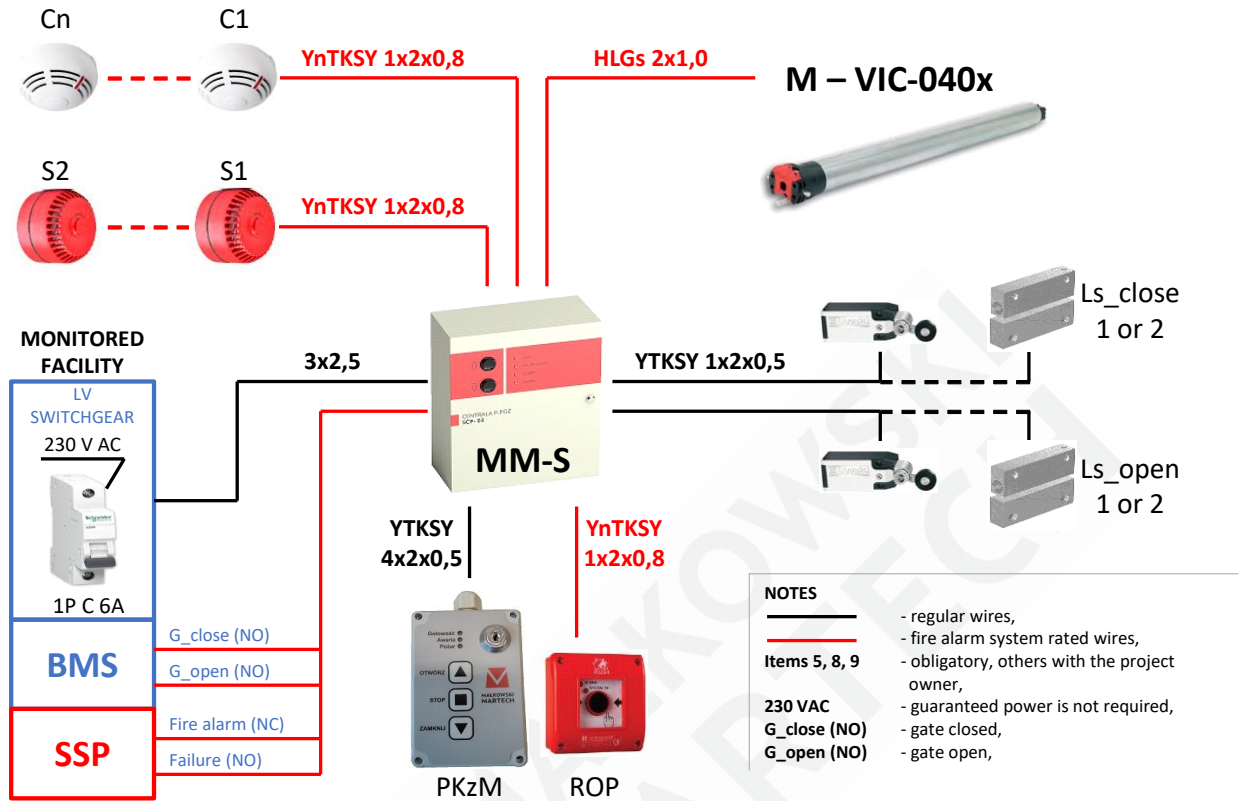



Fig. 5 – MARC-Ok control system with internally-mounted 24 V DC drive unit

No.	Figure item code	Item type	Item name	Item code	Rec. qty	Notes
1	C1 - Cn	point fire detector	optical smoke detector	ID100	2	model ID100, is recommended, max. 6 pcs.
			class A1R heat detector	ID200	2	
			some and heat	ID300	2	
2	C1 - Cn	detector receptacle	standard fire detector receptacle	EB0010	2	qty = detector qty
3	ROP	manual call point	standard manual call point	ROP OP1	1	max. 10 pcs.
4	S1, S2	signalling device	fire alarm sounder, low base	SPP-100	1	max. current 200 mA
5	M	electric drive	internal (tubular)	VIC-040x	1	
6	Ls_close	limit switch „1” mag. sensor „2”	mechanical limit switch, magnetic reed relay switch	KB F1 S11 MS-240-S45	1	application option, selection 1 or 2
7	Ls_open	limit switch „1” mag. sensor „2”	mechanical limit switch, magnetic reed relay switch	KB F1 S11 MS-240-S46	1	
8	PKzM	console	remote console	PKzM	1	
9	MM-S	controller	standard fire alarm control panel	MM-S	1	



 ASSA ABLOY	FIRE PROTECTION CURTAIN DOOR type: MARC-Ok + EI60	number: MM_Ok-5en
	FIRE PROTECTION DEVICE CHARACTERISTICS	revision: 04.2023

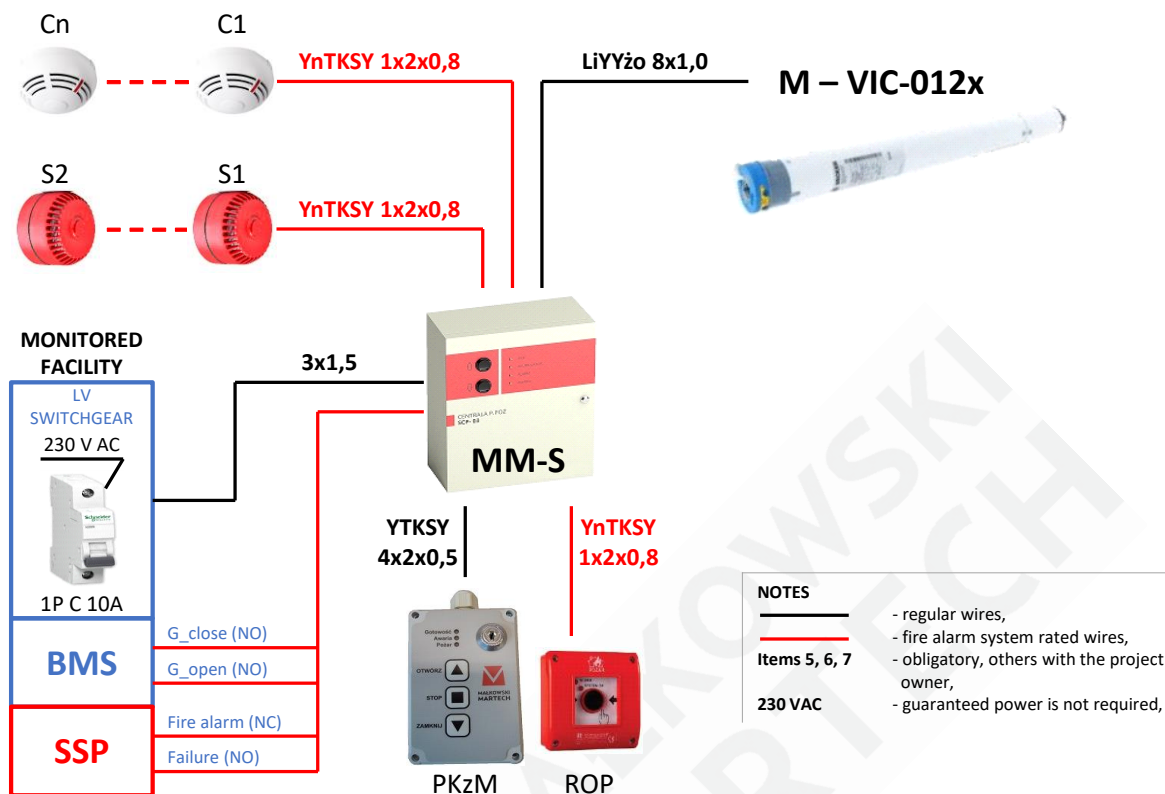



Fig. 6 – MARC-Ok control system with internally-mounted 230 V AC drive unit (gravity closing)

No.	Figure item code	Item type	Item name	Item code	Rec. qty	Notes
1	C1 - Cn	point fire detector	optical smoke detector	ID100	2	model ID100, is recommended, max. 6 pcs.
			class A1R heat detector	ID200	2	
			some and heat	ID300	2	
2	C1 - Cn	detector receptable	standard fire detector receptacle	EB0010	2	qty = detector qty
3	ROP	manual call point	standard manual call point	ROP OP1	1	max. 10 pcs.
4	S1, S2	signalling device	fire alarm sounder, low base	SPP-100	1	max. current 200 mA
5	M	electric drive	Internal (tubular)	VIC-012x	1	
6	PKzM	console	remote console	PKzM	1	
7	MM-S	controller	standard fire alarm control panel	MM-S	1	



 ASSA ABLOY	FIRE PROTECTION CURTAIN DOOR type: MARC-Ok + EI60	number: MM_Ok-5en
	FIRE PROTECTION DEVICE CHARACTERISTICS	revision: 04.2023

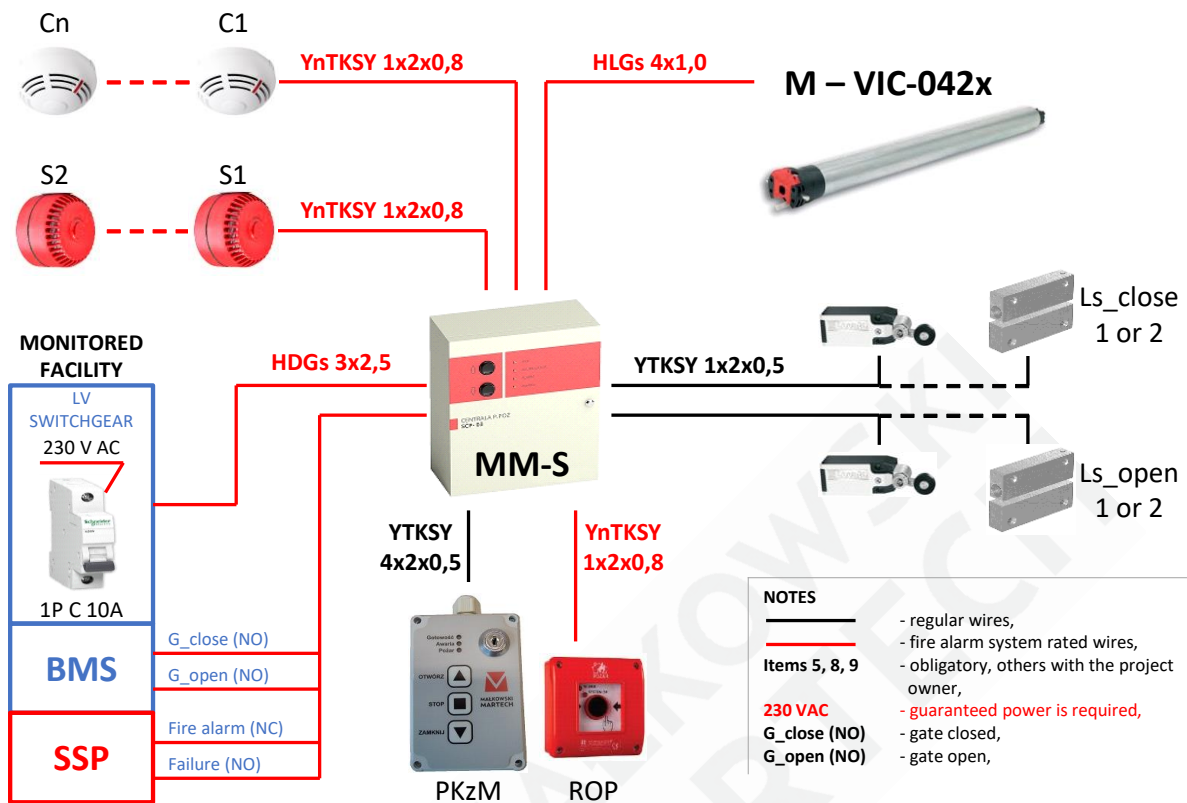



Fig. 7 – MARC-Ok control system with internally-mounted 230 V AC drive unit (guaranteed power)

No.	Figure item code	Item type	Item name	Item code	Rec. qty	Notes
1	C1 - Cn	point fire detector	optical smoke detector	ID100	2	model ID100, is recommended, max. 6 pcs.
			class A1R heat detector	ID200	2	
			some and heat	ID300	2	
2	C1 - Cn	detector receptacle	standard fire detector receptacle	EB0010	2	qty = detector qty
3	ROP	manual call point	standard manual call point	ROP OP1	1	max. 10 pcs.
4	S1, S2	signalling device	fire alarm sounder, low base	SPP-100	1	max. current 200 mA
5	M	electric drive	internal (tubular)	VIC-042x	1	
6	Ls_close	limit switch „1” mag. sensor „2”	mechanical limit switch, magnetic reed relay switch	KB F1 S11 MS-240-S45	1	application option, selection 1 or 2
7	Ls_open	limit switch „1” mag. sensor „2”	mechanical limit switch, magnetic reed relay switch	KB F1 S11 MS-240-S46	1	
8	PKzM	console	remote console	PKzM	1	
9	MM-S	controller	standard fire alarm control panel	MM-S	1	



 ASSA ABLOY	FIRE PROTECTION CURTAIN DOOR type: MARC-Ok + EI60	number: MM_Ok-5en
	FIRE PROTECTION DEVICE CHARACTERISTICS	revision: 04.2023

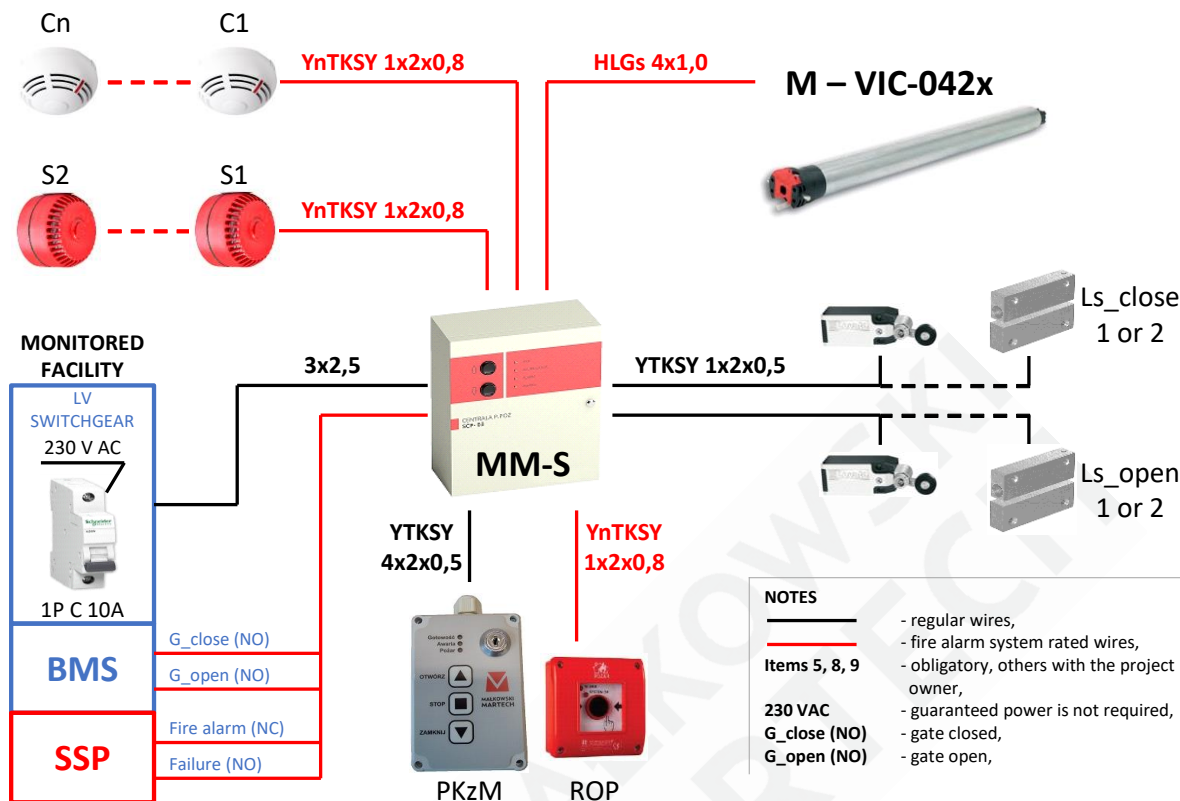



Fig. 8 – MARC-Ok control system with internally-mounted 230 V AC drive unit (with frequency converter)

No.	Figure item code	Item type	Item name	Item code	Rec. qty	Notes
1	C1 - Cn	point fire detector	optical smoke detector	ID100	2	model ID100, is recommended, max. 6 pcs.
			class A1R heat detector	ID200	2	
			some and heat	ID300	2	
2	C1 - Cn	detector receptacle	standard fire detector receptacle	EB0010	2	qty = detector qty
3	ROP	manual call point	standard manual call point	ROP OP1	1	max. 10 pcs.
4	S1, S2	signalling device	fire alarm sounder, low base	SPP-100	1	max. current 200 mA
5	M	electric drive	internal (tubular)	VIC-042x	1	
6	Ls_close	limit switch „1” mag. sensor „2”	mechanical limit switch, magnetic reed relay switch	KB F1 S11 MS-240-S45	1	application option, selection 1 or 2
7	Ls_open	limit switch „1” mag. sensor „2”	mechanical limit switch, magnetic reed relay switch	KB F1 S11 MS-240-S46	1	
8	PKzM	console	remote console	PKzM	1	
9	MM-S	controller	230 V AC current drive controller with frequency converter	MM-S	1	for drives < 600 W or 600 > P > 1500



 ASSA ABLOY	FIRE PROTECTION CURTAIN DOOR type: MARC-Ok + EI60	number: MM_Ok-5en
	FIRE PROTECTION DEVICE CHARACTERISTICS	revision: 04.2023

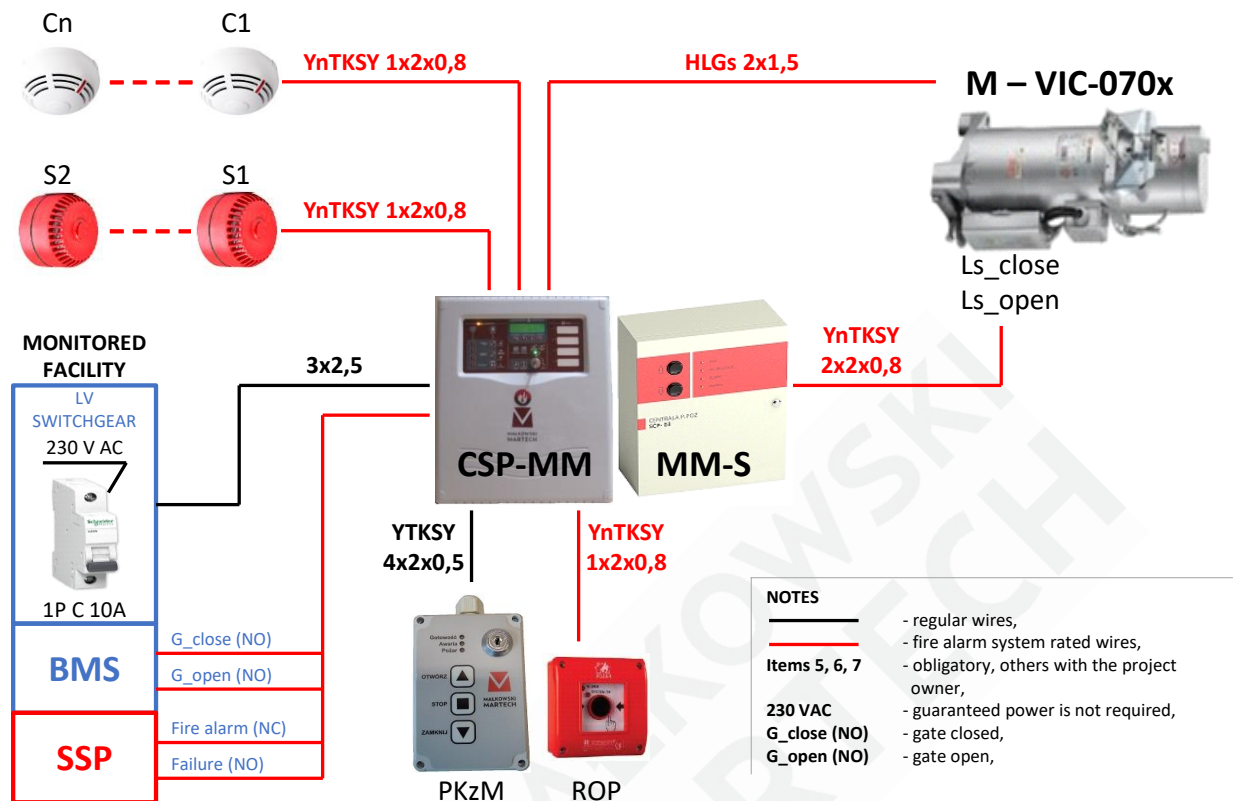

Fig. 9 – MARC-Ok control system with externally-mounted 24 V DC drive unit
variant I – closing/opening with drive; variant II – closing with counterweight, opening with drive

No.	Figure item code	Item type	Item name	Item code	Rec. qty	Notes
1	C1 - Cn	point fire detector	optical smoke detector	ID100	2	model ID100, is recommended, max. 6 pcs.
			class A1R heat detector	ID200	2	
			some and heat	ID300	2	
2	C1 - Cn	detector receptacle	standard fire detector receptacle	EB0010	2	qty = detector qty
3	ROP	manual call point	standard manual call point	ROP OP1	1	max. 10 pcs.
4	S1, S2	signalling device	fire alarm sounder, low base	SPP-100	1	max. current 200 mA
5	M	electric drive	Internal (tubular)	VIC-070x	1	
6	PKzM	console	remote console	PKzM	1	
7	CSP-MM	controller	standard fire alarm control panel	CSP-MM 1(2)	1	

